

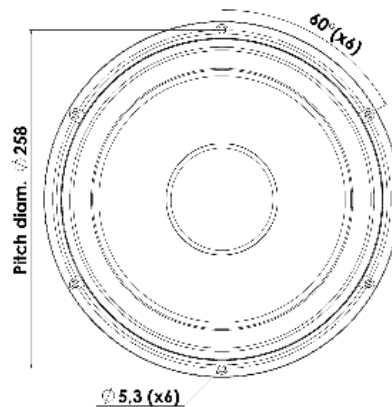

WOOFER

26W/8534G00

The Discovery series offer traditional design, superior sound, a solid construction, and a wide range of variants. Combining these elements - plus a wealth of technical features and finesses - it gives our customers the possibility of acquiring a tailor-made Scan-Speak solution with very good performance at a reasonable low price point!

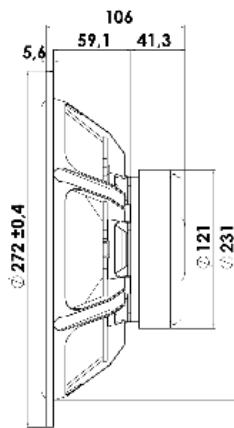

KEY FEATURES:

- Black Anodized Alu Cone
- Magnet System w. Alu Ring
- Low Resonance Freq. 23Hz
- Coated Fibre Glass Dust Cap
- Die cast Alu Chassis vented below spider

T-S Parameters

Resonance frequency [fs]	23 Hz
Mechanical Q factor [Qms]	9.12
Electrical Q factor [Qes]	0.42
Total Q factor [Qts]	0.40
Force factor [Bl]	10.1 Tm
Mechanical resistance [Rms]	0.80 kg/s
Moving mass [Mms]	50.5 g
Suspension compliance [Cms]	0.95 mm/N
Effective diaph. diameter [D]	211 mm
Effective piston area [Sd]	350 cm ²
Equivalent volume [Vas]	150 l
Sensitivity (2.83V/1m)	89 dB
Ratio Bl/√Re	4.23 N/√W
Ratio fs/Qts	57.5 Hz

Notes:

IEC specs. refer to IEC 60268-5 third edition.
All Scan-Speak products are RoHS compliant.
Data are subject to change without notice.
Datasheet updated: May 5, 2011

Electrical Data

Nominal impedance [Zn]	8 Ω
Minimum impedance [Zmin]	6.4 Ω
Maximum impedance [Zo]	117 Ω
DC resistance [Re]	5.7 Ω
Voice coil inductance [Le]	0.96 mH

Power Handling

100h RMS noise test (IEC 17.1)	80 W
Long-term max power (IEC 17.3)	150 W

Voice Coil and Magnet Data

Voice coil diameter	38 mm
Voice coil height	18 mm
Voice coil layers	2
Height of gap	6 mm
Linear excursion	± 6 mm
Max mech. excursion	± 12 mm
Unit weight	2.9 kg



WOOFER

26W/8534G00

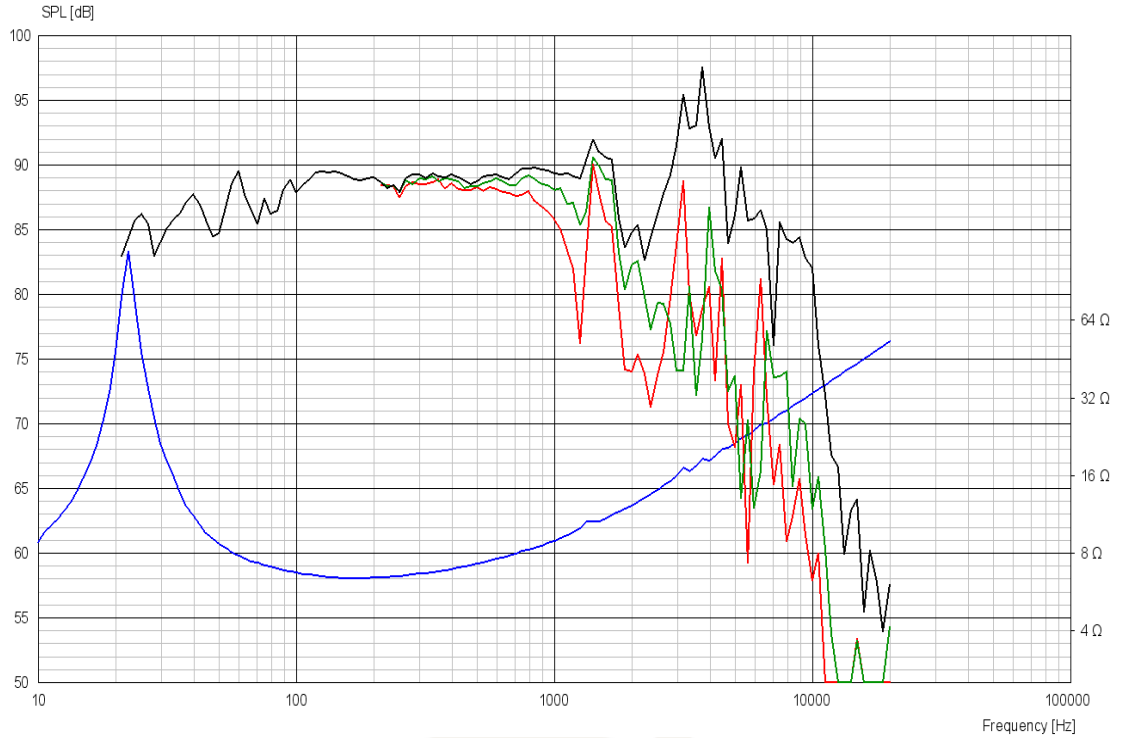

Advanced Parameters (Preliminary)

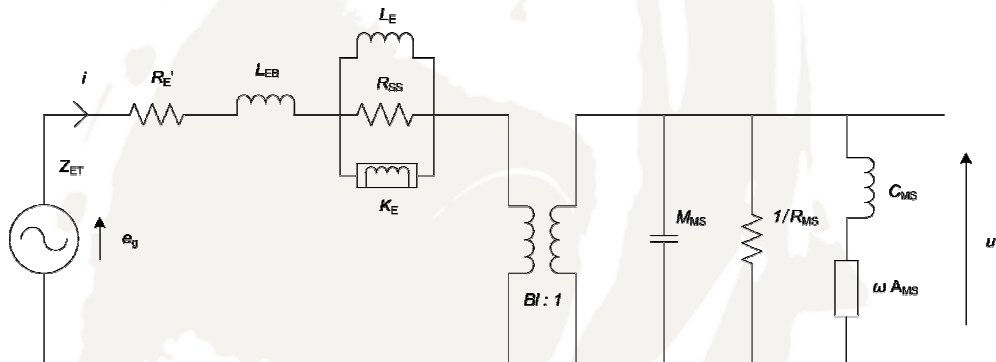

Electrical data

Resistance [Re']	6.08 Ω
Free inductance [Leb]	0.0726 mH
Bound inductance [Le]	1.15 mH
Semi-inductance [Ke]	0.143 SH
Shunt resistance [Rss]	2290 Ω

Mechanical Data

Force Factor [BI]	9.60 Tm
Moving mass [Mms]	52.35 g
Compliance [Cms]	0.862 mm/N
Mechanical resistance [Rms]	0.151 kg/s
Admittance [Ams]	0.0713 mm/N